

MARINE SELF CONTAINED AIR CONDITIONING SYSTEM

RadAir™

By  mabru

INSTALLATION MANUAL

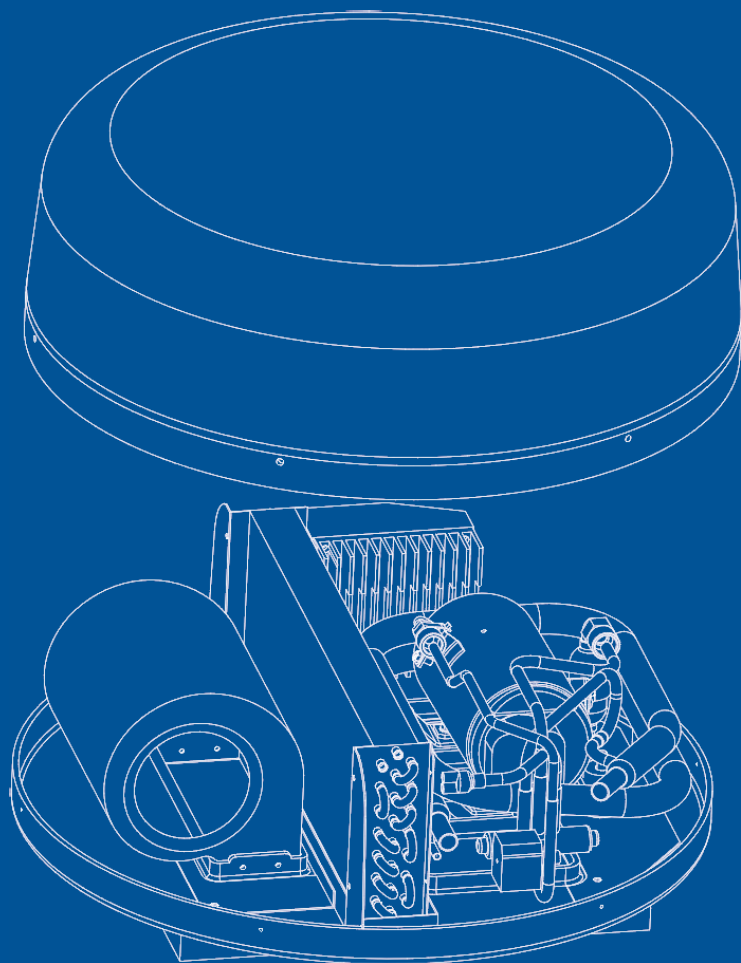



CERTIFIED QUALITY. TRUSTED PERFORMANCE.

Every Mabru Power Systems unit is tested and certified to **CE** and **RoHS** standards, ensuring reliable performance and long-term durability.

Mabru Power Systems — Powering Comfort. Built on Trust.



The RadAir Rooftop Air Conditioning Unit should be installed by a qualified and experienced installer. Due to the wide range of roof materials, structural designs, and vessel configurations, installation methods may vary. Improper installation may result in unit failure, damage to the mounting surface, or safety hazards. Mabru is not responsible for damage or injury resulting from incorrect installation. Please consult a professional to ensure proper fitment, sealing, and electrical connection for your specific application.

TABLE OF CONTENTS

MABRU INSTALLATION MANUAL

03	Introduction	22	Wire Diagrams
04	Safety Precautions	24	Quick Start / Operations Checklist
06	Design Considerations	25	Display Menu Options
07	Custom Plenum Fabrication Guide	27	Preventive Maintenance / Winterization
08	Installation Overview	28	Dimensions
10	Optional Installation Kit	29	Parts Diagram
11	Placement Of The RadAir™	30	Error Codes
12	RadAir™ Unit Placement Guidelines	34	Serial Number Placement
13	Mounting The RadAir™	35	Warranty And Return Policy
14	Installation / Seawater System		
15	RadAir™ Pump Specifications		
18	Condensate Drain / Condenser Outflow		
19	Condensate Drainage Options		
20	Installation / Electrical		

INTRODUCTION

MABRU INSTALLATION MANUAL

Thank you very much for purchasing our RadAir™ RTSC12DOME 12,000 BTU self-contained 12V DC marine rooftop air conditioner. Improper installation can result in unsatisfactory performance and or premature failure.

Before proceeding with the installation, please read this manual completely.

If you need assistance, the please feel free to contact us by emailing support@mabrumarine.com or calling (888) 818-2814. Our hours of operation are M-F 8:00AM to 4:30 PM ET.

Warranty information is available on [page 35](#) of this manual.

Mabru Power System's specifications are subject to change without prior notice.

Sizing marine air conditioning systems involves more than just calculating the cubic footage of the space to be cooled.

Here are some key factors to consider:

1. Insulation Quality:

Poor insulation will allow more heat to enter the space, requiring a larger capacity unit to maintain a comfortable temperature.

2. Windows and Doors:

Windows, especially if they are not tinted or insulated, can let in significant amounts of heat from the sun. Doors that are frequently opened can also introduce warm air into the space.

3. Heat Load from Equipment:

Engines, generators, and other onboard equipment can generate significant heat, which the air conditioning system will need to offset. The more equipment running, the higher the heat load.

4. Location and Climate:

The environment where the vessel operates plays a significant role. Tropical climates require more cooling power compared to cooler regions.

5. Airflow and Ventilation:

Proper airflow and ventilation ensure that cool air is distributed evenly throughout the space and that hot air is effectively removed.

6. Occupancy:

The number of people onboard affects the cooling load, as human bodies generate heat.

7. Sun Exposure:

The amount of direct sunlight the vessel receives, especially on decks and cabins, can significantly increase the cooling demand.

8. Humidity:

High humidity levels can make the air feel warmer and require the air conditioning system to work harder to remove moisture from the air.

9. Hull Color:

The color of the hull can influence how much heat is absorbed by the vessel. Dark colored hulls absorb more heat from the sun, raising the interior temperature and the cooling load.

Taking all these factors into account will help in selecting the right size and type of marine air conditioning system for your vessel, ensuring optimal performance and comfort.

SAFETY

PRECAUTIONS

1. Engine Room and Condensate Drain

Never install air conditioning in engine rooms. If a condensate drain is draining into a bilge connected to an engine room, then a P-trap must be used. Follow ABYC standards for condensate drains. Do not terminate condensate drain lines within 3 feet, or 915 mm or from any engine or generator exhaust system. Do not install the air conditioner near LPG/CPG or gasoline engines. Please follow ABYC standard H-27 for hose types, Seacocks, and thru-hull connections.

2. Electrical Shock

Disconnect power at the panel or power source before opening any cover. Mistakes here may result in injury or death. If you are not sure, please call a qualified marine electrician. The electrical components associated with your marine air conditioning installation must be grounded and comply with the manufacturer's recommendations. This may include batteries, battery chargers, inverters, battery-to-battery chargers, as well as other devices.



3. Ignition Protection

Mabru air conditioners do not meet the requirements for ignition protection. Do not install in areas that are connected to gasoline engines, LPG/CPG, or other flammable materials.

4. Hose Clamps

Follow ISO standards for all marine air conditioning plumbing and use two hose clamps in reverse directions on all connections on the seawater pump circuit. Marine-grade, stainless steel hose clamps are required for all Mabru air conditioning installations.

5. Confirm Structural Integrity

Before installation, verify that the roof is structurally capable of supporting the full weight of the unit under all sea conditions, including rough water and vessel movement. Reinforce if necessary.

SPECIFICATIONS

OVERVIEW

12,000 BTUs of heating / cooling from above

This 12V DC self-contained rooftop air conditioning unit enables efficient open cockpit heating and cooling without the need to worry about space and / or installation constraints.

The variable speed compressor draws less power than traditional on/off air conditioning units, making it ideal for battery-powered applications

RadAir™ was engineered using top-tier components to ensure peak performance and durability:

- Copper antimicrobial evaporator
- B30 Cupronickel condensing coil
- Digital Color touch display
- Raw water pump - 350 GPH
- High velocity blower



Download RadAir™ Specifications

Cooling Capacity (BTU/h)	12000
Heating Capacity (BTU/h)	12300
Power Source	12V DC
Cooling Amp Draw	22-44
Heating Amp Draw	28-48
Fan Blower (CFM) (Low/Med/High)	310/380/440
Refrigerant	R-134a
Minimum Return Air Grille Size (sq in) [sq cm]	48 [309.68]
Minimum Supply Air Grille Size (sq in) [sq cm]	48 [309.68]
Seawater Pipe Inside Diameter (in) [mm]	5/8 [15.88]
Unit Weight (lbs) [kg]	55 [24.95]
Unit Dimensions (Diameter x Height) (in) [mm]	23 x 8 [584.2 x 203.2]

DESIGN CONSIDERATIONS

1. Carbon Monoxide Migration

It is critical to keep carbon monoxide out of living areas. Please be aware of possible carbon monoxide sources. Several are engine rooms and condensate drains that are connected to engine rooms through a bilge. For condensate drain requirements. A minimum of 5/8" inside diameter hose should be used for the condensate drain hose. Condensate drains must be installed so they are continuously running downhill. A P-trap in the condensate drain line is acceptable and may help to seal out carbon monoxide. Never install air conditioners in engine rooms. For condensate drain requirements please see ABYC section A-6.5.11.

2. Vents Requirements

- **Supply Vent:** Vents may be selected based on customer preference, provided the minimum open area is 48 square inches. A popular option is the MSI PGA 4" x 12" louvered grille.
- **Return Vent:** The return vent must include a filter to protect the unit from debris and ensure efficient operation.
- **Return Air And Cold Air Vents:** are in the ceiling under the unit. The unit can be drained onto the roof or plumbed to a shower sump and pumped overboard. It can also be drained to a bilge. If draining to a bilge, please use a P-trap.



3. Water Flow to the Air Conditioner

A forward-facing speed scoop is mandatory as well as a proper seacock, strainer, and pump. These items must be installed correctly and at least 1 foot below the waterline. Mabrú pumps are not self priming. A bleeding valve is recommended to facilitate the removal of trapped air. The strainer will need to be periodically cleaned and should be located in a space that is easy to access.

4. Electrical Box Location

The Electrical box is accessible by removing the top of the dome. The circuit board is the same as the SC12DC.



CUSTOM PLENUM FABRICATION GUIDE

IMPORTANT NOTE: Styrofoam is not marine-grade (or flame-retardant.) Use only in dry, insulated spaces or for mock-ups, and consider sealing or coating for added durability.

MATERIALS NEEDED

- Rigid foam insulation (1/2"–1" thick)
- Foam-safe adhesive
- Utility knife or hot wire cutter
- Tape measure / straight edge
- High-density foam tape
- Foil tape or duct tape
- Caulking or silicone (optional for seams)

NOTE: Due to variations in roof thickness and design, a custom plenum may be required to ensure proper air distribution. Air separation is required between Return air and cold air output. This can be accomplished with a custom plenum made from foam panels or stacked high density foam tape.

The RadAir relies on a clear separation of return air and supply air at the unit's immediate vicinity. Always verify roof thickness before installation, as it may vary significantly by vessel model.

For single-layer roofs, standard installation with interior vents may be sufficient.

Step-By-Step Instructions

1. Measure the Ceiling Cavity

Measure from bottom of the RadAir unit to interior ceiling. Mark cutout dimensions needed for airflow.

2. Cut the Panels

Cut panels for the plenum walls. A separation is required between return air and cold air output.

3. Assemble the Plenum

Fasten walls together – and test fit between roof opening and ceiling. Apply foam tape to top and bottom edges for a snug seal with RadAir unit.

4. Install the Plenum

Install the plenum in the ceiling opening and secure against RadAir unit using adhesive or foil tape.

5. Attach Vent or Grille

Cut openings for cold air and return air vents. Securely attach it, test for airflow and leaks. Ensure there is no air communication between the two vents, and that the vents are within the plenum walls.

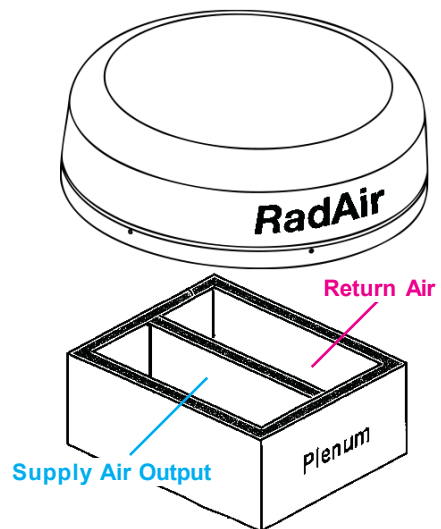

INSTALLATION

OVERVIEW

Before installation, please read these instructions completely and then plan for all connections. This includes condensate drains, seawater inlet and outlet, seacock, sea strainer, pump, hoses, electrical power connections, and the location of the control panel.

INCLUDED ACCESSORIES WITH THE AIR CONDITIONER



1. Color touch display with black bezel.
2. Backing plate for RadAir™ mounting
3. 15 ft display cable. (Standard CAT5 ethernet cable can be used for a longer run, up to 50'.)
4. (RTSC12DOME) RadAir™ comes with a 350 GPH 12V raw water pump.
5. #8 Hose clamps for 5/8" PVC Air-Con Hose
6. Silicone Elbows are provided for condenser water input and output.
7. Clamp-Aids to be applied at the end of the #8 Hose clamps

INSTALLATION OVERVIEW

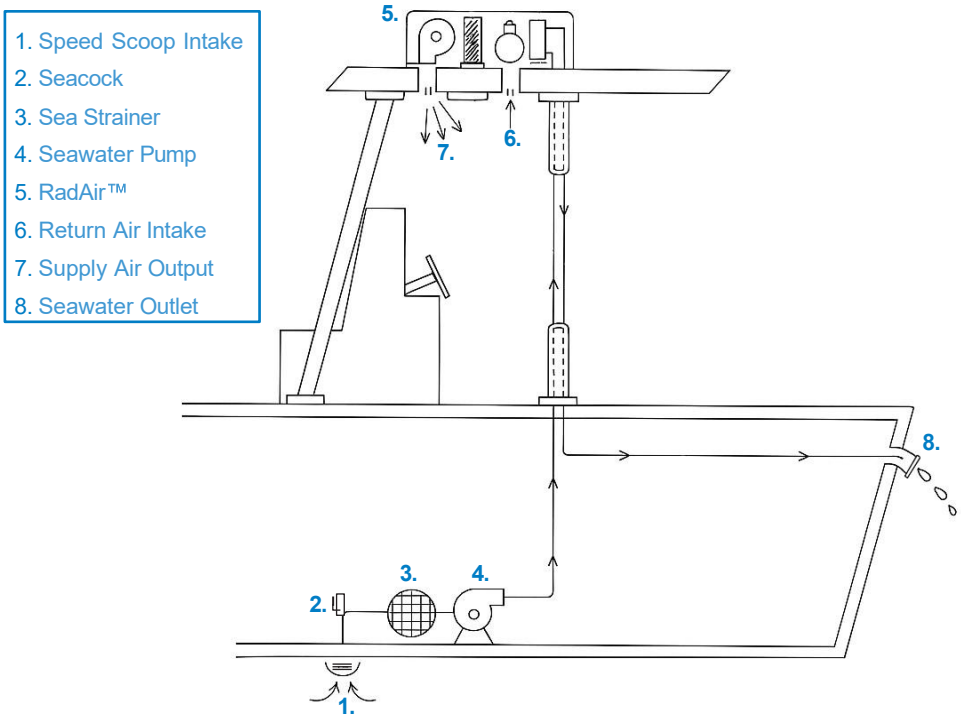

INSTALLATION SAFETY

Qualified Installer Required: Installation must be performed by a qualified professional familiar with 12V DC systems.

Disconnect Power: Always disconnect the battery and shore power before installation, maintenance, or inspection.

Support the Unit: Use caution when lifting or placing the unit on the roof. Always use two people or mechanical assistance to avoid injury or damage.

Seal Openings: Ensure all roof penetrations are properly sealed with marine-grade sealant to prevent water intrusion.

Secure Mounting: Fasten unit securely using all provided mounting points. Do not rely solely on adhesive or foam tape for support.

Clearance Warning: The RadAir unit may increase the overall height of the vessel. Always account for added clearance when navigating under bridges, overhangs, or during transport.

Confirm Structural Integrity
Before installation, verify that the roof is structurally capable of supporting the full weight of the unit under all sea conditions, including rough water and vessel movement. Reinforce if necessary.

OPTIONAL INSTALLATION KIT (Sold Separately)

Basic Installation components for the installation of the RadAir™ unit include:

- (1) Mabru 1/2" Pump Strainer & Bracket
- (1) GROCO STH-500 W 1/2" Scoop THRU-HULL with nut
- (1) GROCO IBV-500 1/2" NPT Bronze Ball Valve
- (1) SEAFIT 90 Degree Nylon/Stainless Steel Mushroom Thru-Hulls for 5/8" Hose
- (23) #8 Hose Clamp
- (23) Clamp-Aid Blue 1/2", 5/16"
- (50) 5/8" ID White PVC Air-Con Hose

(1) RadAir Hardware Kit

- (4) Metric machine screws, Phillips pan head, Stainless steel 316 (A-4), 5mm x 0.8mm x 80mm
- (4) Metric lock washers, Stainless steel 316 (A-4), 5mm

- (4) Metric fender washers, Stainless steel 316 (A-4), 5mm x 15mm
- (2) 3/4 Inch Male GHT x 1/2 Inch Female
- (1) NPT Double Threaded Bulkhead Water Tank Connector (water in/out)
- (1) NPT1/2 PVC Bulkhead Fitting, 1/2 Inch Plastic Water Tank Connector (drain)

Fittings

- (5) 1/2" PVC Barbed Insert Male Adapter (MIPT x Insert)
- (4) 1/2" 90° PVC Insert Elbow (Insert x MIPT)
- (1) 1/2" 90° PVC Insert Elbow (Insert x FIPT)
- (1) 1/2" PVC Barbed Insert Female Adapter (FIPT x Insert)
- (1) Bleeding valve kit 5/8"



PLACEMENT

OF THE MABRU AIR CONDITIONER

1. Do not install the air conditioner in the engine room or a bilge connected to the engine room.
2. If draining the condensate to a bilge, place the drain line as close to a bilge pump as possible. A P-trap is also recommended when draining to the bilge. A shower sump box and pump may also be used for the condensate drain, and this is the preferred method to eliminate sitting water in the bilge. Our marine air conditioners can produce as much as 5 gallons of condensate water per hour.
3. Mount the air conditioner on the roof over the area that it will cool. If the roof is thicker or the boat has a double roof, you may need to make a custom air plenum
4. Use a speed scoop on the outside of the intake thru-hull. The slotted side of the scoop must face forward and not be obstructed by any hull steps, intakes, or transducers in the hull forward of the air conditioner intake.
5. Install the thru-hull and seacock as low and as far back in the boat as possible in an accessible location for inspection and maintenance.
6. The color touch display should be installed in a dry location inside the boat. **The current color touch display is not water-proof.**
7. Before installation, verify that the roof is structurally capable of supporting the full weight of the unit under all sea conditions, including rough water and vessel movement. Reinforce if necessary.



RadAir™ UNIT PLACEMENT GUIDELINES

The RadAir rooftop air conditioner is a non-ducted system, designed to deliver cooled air directly into the space below.

1. Install Directly Above Target Area: The unit must be installed directly over the area you intend to cool/ heat. Air is discharged straight down through the roof into the interior.

2. Interior Vents Required: Vents must be installed directly beneath the unit to allow for proper airflow. Attempts to duct or re-direct air through additional channels, may reduce performance if not done correctly.

3. Avoid Obstructions: Choose a location with a clear interior ceiling space for vent installation and enough structural support on the roof for the unit's weight.

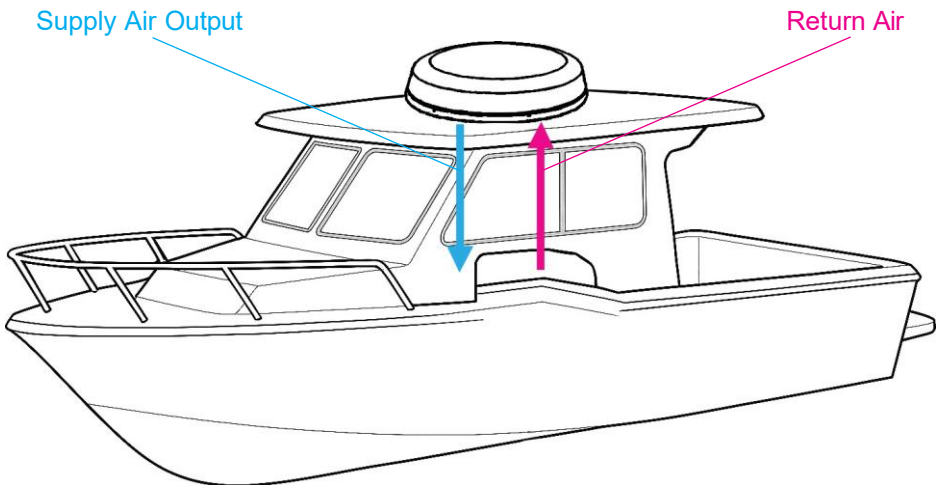

MOUNTING THE RadAir™

- Use the backing plate as a template for the roof cutouts once final placement of the unit has been determined.
- Use marine-grade sealant between the unit's gasket and the roof to ensure a watertight seal.
- Find the holes in the backing plate for the mounting hardware, shown below, which thread into the chassis of the unit to secure the unit on the roof. Mark the (4) hole locations.

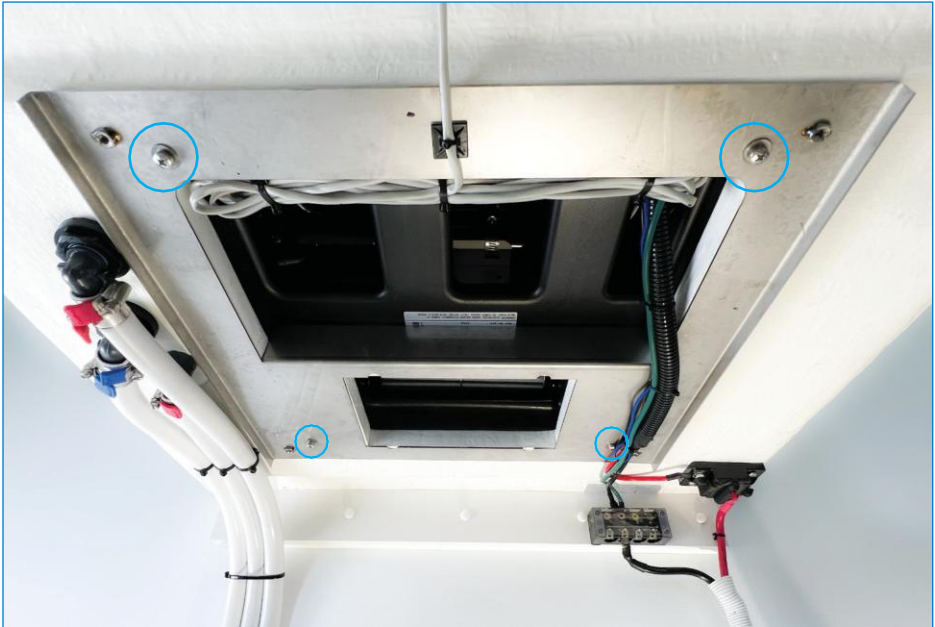

- Use a $\frac{1}{4}$ " drill bit for the hardware and ensure that the hardware is the correct length. Up to 3" excess length into the unit is acceptable, but not more. The mounting hardware must be M5 X .08. Ensure that the hardware is sized appropriately for the roof thickness.
- When installing the hardware, blue thread locker and a lock-washer must be used. The hardware must be torqued to 11ft-Lbs.

NOTE: We recommend passing the wire harness and display cable through the return opening to reduce the number of openings required on the roof, but they can go through additional holes with a cable gland installed.

NOTE: In our optional installation kit, we include bulkhead fittings for the drain connection as well as seawater in and out. We recommend using bulkhead fittings to prevent water ingress. These must be installed before securing the unit as there is insufficient access to install these fittings once the unit is secured.



INSTALLATION/ SEAWATER SYSTEM

All Mabru marine air conditioners are water-cooled and require a seawater intake system. This system is comprised of a speed scoop, intake thru-hull fitting, seacock, sea strainer, and water pump. These components must be installed at least one foot below the boat's waterline to ensure proper water intake for cooling and efficient operation.

The speed scoop should be facing the bow or front of the boat and as far underwater as possible. The speed scoop must remain underwater in all conditions. If air gets into the seawater inlet, the pump will

stop pumping water. A bleeding valve can be used to clear the air from the pump.

Water inlets should not be shared with galleys, heads, or any other pumps. Each air conditioner should have its own thru-hull. The intake cannot be mounted aft of hull steps or any other hull obstruction that will affect the water flow to the intake. Components such as transducers, other intakes, or strikes can cause cavitation in the water flowing to the intake which will introduce air into the air conditioner's sea water intake and possibly cause airlocks.



Forward-Facing Speed Scoop Thru-Hull Recommended (Pictured)



Bronze Seacock Recommended (Pictured)

ALL THRU-HULLS MUST HAVE THE APPROPRIATE SEACOCK THAT MEETS ABYC SPECIFICATIONS.

A sea strainer is mandatory for air conditioning sea water systems. Sea strainers should be checked and cleaned regularly. A dirty sea strainer may damage your seawater pump and void its warranty as well as impact

the performance of your air conditioner(s). All hoses must be reinforced and marine grade. Follow ABYC specifications for all thru-hulls and bonding of metallic thru-hulls.

INSTALLATION/ SEAWATER SYSTEM



Mabru ½" or ¾" Sea Strainers, Depending on Size of Water Lines (Pictured)



Mabru 350 GPH Pump (Pictured)

Mabru seawater pumps are not self-priming. The pump may be mounted horizontally or vertically, with the discharge higher than the inlet; otherwise, the pump will be prone to air-locks. The pump head should be rotated in the direction of the water flow. The pump

should be mounted level with or above the sea strainer, but still 1 foot below the waterline. RadAir™ (RTSC12DOME) uses a Mabru 350 GPH 12V DC pump, which is included. The Mabru 350 GPH pump has ½" inch NPT threads.

RadAir™ PUMP SPECS



	350 GPH
Power Source	12V DC
Amp Draw	4.5
Submersible	Yes
Max Head (ft) [m]	35 [10.7]
Gallons Per Hour [Liters]	350 [1325]
Inlet x Outlet (in) [mm]	0.5 [12.7]
Height (in) [mm]	3.19 [81]
Width (in) [mm]	3.19 [81]
Length (in) [mm]	4.0 [101.6]
Weight (lbs) [g]	1.55 [703.1]
AC Power Supply	No

INSTALLATION/ SEAWATER SYSTEM

The air conditioning water discharge should flow upward and exit through a thru-hull fitting located above the waterline to allow for visual inspection. The thru-hull should be mounted within 18 inches of the waterline to minimize water splashing noise. Use a reinforced marine-grade 5/8"inch hose

for the discharge line, ensuring there are no high spots or loops to prevent air locks and maintain efficient water flow. All air conditioning water lines should be double hose clamped with the clamps reversed. Proper 316 stainless steel marine-grade hose clamps must be used.



Above is a proper example of a pump installation with our 1/2" bleeding valve on the outlet of the pump.

INSTALLATION/ SEAWATER SYSTEM

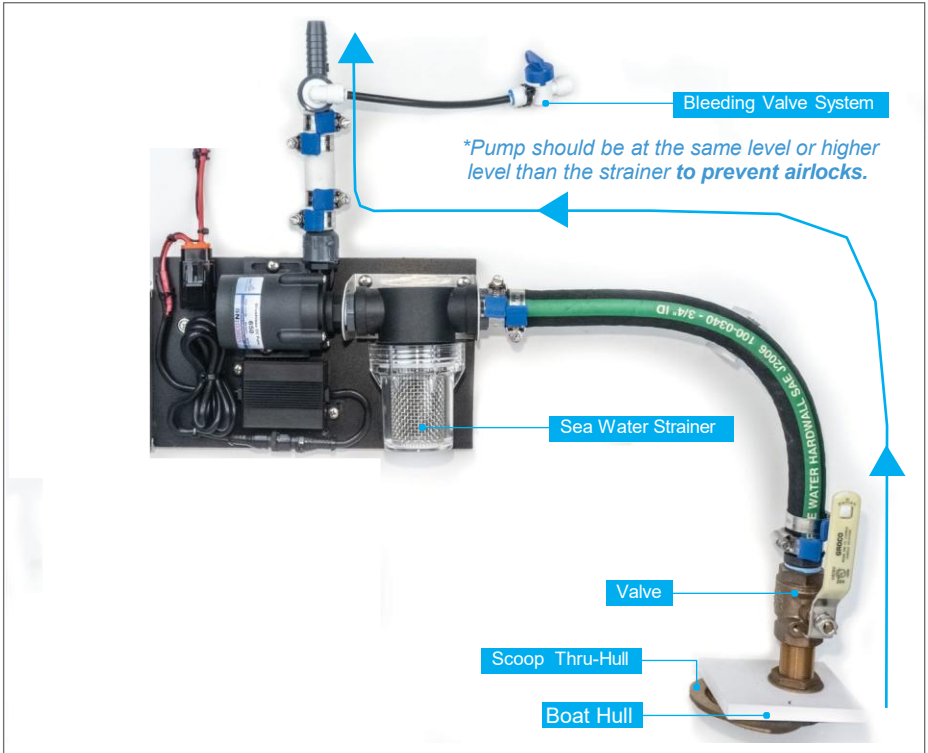

Above is a proper example of a pump installation with our 1/2" bleeder valve on the outlet of the pump.

PROPER CONDENSATE DRAIN AND CONDENSER OUT FLOW

Do not connect condensate drains to the outflow of the air conditioner. If a blockage occurs, water could be pumped into the condensate drain pan, potentially flooding the boat and causing damage to the air

conditioner. Mabru 12V DC air conditioners require the chassis to be grounded to the ship's ground, using the green grounding wire provided.



If the condensate drains into the bilge, a P-trap must be installed to prevent vapors from entering the living space. Alternatively, the ideal method for removing condensate is by using a sump box and pump system to discharge the water overboard. Our air conditioners can produce up to

5 gallons of condensate per hour. The drain pan uses a standard 1/2" inch NPT pipe thread fitting for connection. After the installation is complete, please test the drain by pouring 1 gallon of water into the drain pan as a test for proper drainage.

NOTE: Always ensure drain lines are properly secured and routed downward to prevent backflow or water pooling.

CONDENSATE DRAINAGE OPTIONS

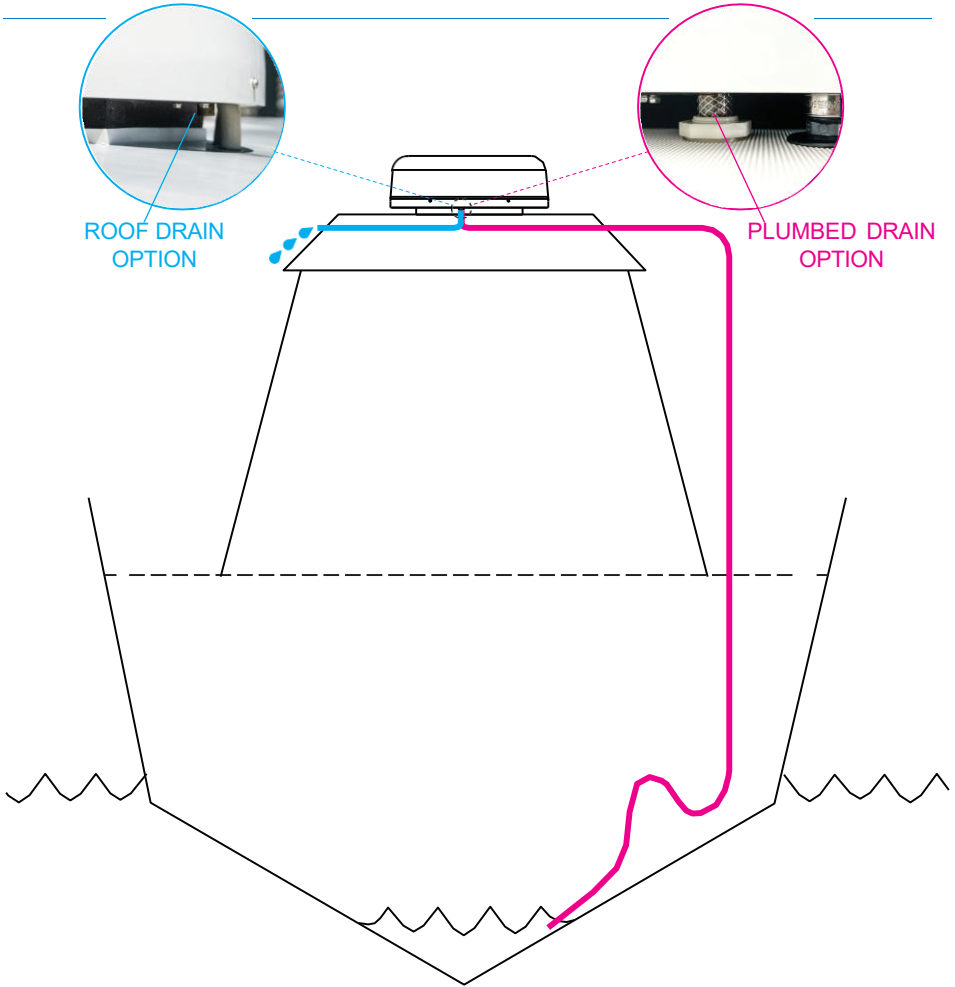

Roof Drain Option

Condensate can drain directly onto the roof of the boat.

Plumbed Drain Option

Alternatively, condensate can be drained into a shower sump or routed to the bilge using an appropriate drain hose.

NOTE: Always ensure drain lines are properly secured and routed downward to prevent backflow or water pooling.

INSTALLATION/ ELECTRICAL

THE FOLLOWING IS A SUMMARY OF PROPER ELECTRICAL CONNECTIONS

1. All crimp connections should meet ABYC standards and be watertight. Heat shrink tubing should be used to ensure these connections are watertight. Fork or ring terminals must be used on all connections made within the electrical box. Bare wires cannot be connected to the power terminals.
2. All 115/230 V AC power feeds must be installed and grounded following ABYC standards.
3. The proper circuit protection must be used. On the RadAir™ RT12DC, we recommend a 60A breaker.
4. If installing more than one air conditioner, each one will need to have a dedicated circuit breaker.
5. The color touch display is connected to the conditioner's control box with a standard 15' CAT5 ethernet cable. If the cable is not long enough, a longer cable, up to 50', can be purchased from any electronics store. The color touch display must be installed in a dry location inside the boat. **The current color touch display is not water-proof.**
6. For proper wire sizes, please use a wire gauge calculator or ABYC chart. 3% is the maximum recommended voltage drop. On DC calculations, length is round trip, not one way.
7. Our 12V DC RadAir™ (RT12DC) needs to have the chassis grounded or bonded to the ship's ground. This is seen in the picture below.



DC GROUNDING WIRE

For Mabru 12V DC air conditioners (RTSC12DOME RadAir™), bonding or grounding to the ship's ground is required. Failure to ground the DC air conditioner will void the unit's warranty and increase the risk of failure.



Grounding
Wire

WIRE SIZING TABLE/ 3% LOSS

CIRCUIT LENGTH	CIRCUIT TYPE				CURRENT FLOW IN AMPS																
	10% VOLTAGE DROP Non Critical		3% VOLTAGE DROP Critical		5A	10A	15A	20A	25A	30A	40A	50A	60A	70A	80A	90A	100A	120A	150A	200A	
	0 to 20 ft.	0 to 6.1 M	0 to 6 ft.	0 to 1.8 M	16 AWG	14 AWG	14 AWG	14 AWG	12 AWG	10 AWG	8 AWG	6 AWG	4 AWG	2 AWG	0 AWG	4 AWG	2 AWG	1 AWG	0 AWG	1 AWG	0 AWG
	30 ft.	9.1 M	10 ft.	3.0 M	14 AWG	12 AWG	12 AWG	12 AWG	10 AWG	8 AWG	6 AWG	4 AWG	2 AWG	0 AWG	4 AWG	2 AWG	1 AWG	0 AWG	1 AWG	0 AWG	1 AWG
50 ft.	15.2 M	15 ft.	4.6 M	14 AWG	12 AWG	12 AWG	12 AWG	10 AWG	8 AWG	6 AWG	4 AWG	2 AWG	0 AWG	4 AWG	2 AWG	1 AWG	0 AWG	1 AWG	0 AWG	1 AWG	0 AWG
65 ft.	19.8 M	20 ft.	6.1 M	14 AWG	12 AWG	12 AWG	12 AWG	10 AWG	8 AWG	6 AWG	4 AWG	2 AWG	0 AWG	4 AWG	2 AWG	1 AWG	0 AWG	1 AWG	0 AWG	1 AWG	0 AWG
80 ft.	24.4 M	25 ft.	7.6 M	14 AWG	12 AWG	12 AWG	12 AWG	10 AWG	8 AWG	6 AWG	4 AWG	2 AWG	0 AWG	4 AWG	2 AWG	1 AWG	0 AWG	1 AWG	0 AWG	1 AWG	0 AWG
100 ft.	30.5 M	30 ft.	9.1 M	14 AWG	12 AWG	12 AWG	12 AWG	10 AWG	8 AWG	6 AWG	4 AWG	2 AWG	0 AWG	4 AWG	2 AWG	1 AWG	0 AWG	1 AWG	0 AWG	1 AWG	0 AWG
130 ft.	39.6 M	40 ft.	12.2 M	14 AWG	12 AWG	12 AWG	12 AWG	10 AWG	8 AWG	6 AWG	4 AWG	2 AWG	0 AWG	4 AWG	2 AWG	1 AWG	0 AWG	1 AWG	0 AWG	1 AWG	0 AWG
165 ft.	50.3 M	50 ft.	15.2 M	14 AWG	12 AWG	12 AWG	12 AWG	10 AWG	8 AWG	6 AWG	4 AWG	2 AWG	0 AWG	4 AWG	2 AWG	1 AWG	0 AWG	1 AWG	0 AWG	1 AWG	0 AWG
200 ft.	61.0 M	60 ft.	18.3 M	14 AWG	12 AWG	12 AWG	12 AWG	10 AWG	8 AWG	6 AWG	4 AWG	2 AWG	0 AWG	4 AWG	2 AWG	1 AWG	0 AWG	1 AWG	0 AWG	1 AWG	0 AWG
		70 ft.	21.3 M	14 AWG	12 AWG	12 AWG	12 AWG	10 AWG	8 AWG	6 AWG	4 AWG	2 AWG	0 AWG	4 AWG	2 AWG	1 AWG	0 AWG	1 AWG	0 AWG	1 AWG	0 AWG
		80 ft.	24.4 M	14 AWG	12 AWG	12 AWG	12 AWG	10 AWG	8 AWG	6 AWG	4 AWG	2 AWG	0 AWG	4 AWG	2 AWG	1 AWG	0 AWG	1 AWG	0 AWG	1 AWG	0 AWG
		90 ft.	27.4 M	14 AWG	12 AWG	12 AWG	12 AWG	10 AWG	8 AWG	6 AWG	4 AWG	2 AWG	0 AWG	4 AWG	2 AWG	1 AWG	0 AWG	1 AWG	0 AWG	1 AWG	0 AWG
		100 ft.	30.5 M	14 AWG	12 AWG	12 AWG	12 AWG	10 AWG	8 AWG	6 AWG	4 AWG	2 AWG	0 AWG	4 AWG	2 AWG	1 AWG	0 AWG	1 AWG	0 AWG	1 AWG	0 AWG
		110 ft.	33.5 M	14 AWG	12 AWG	12 AWG	12 AWG	10 AWG	8 AWG	6 AWG	4 AWG	2 AWG	0 AWG	4 AWG	2 AWG	1 AWG	0 AWG	1 AWG	0 AWG	1 AWG	0 AWG
		120 ft.	36.6 M	14 AWG	12 AWG	12 AWG	12 AWG	10 AWG	8 AWG	6 AWG	4 AWG	2 AWG	0 AWG	4 AWG	2 AWG	1 AWG	0 AWG	1 AWG	0 AWG	1 AWG	0 AWG
		130 ft.	39.6 M	14 AWG	12 AWG	12 AWG	12 AWG	10 AWG	8 AWG	6 AWG	4 AWG	2 AWG	0 AWG	4 AWG	2 AWG	1 AWG	0 AWG	1 AWG	0 AWG	1 AWG	0 AWG

Although this process uses information from ABYC E-11 to recommend wire size and circuit protection, it may not cover all of the unique characteristics that may exist on a boat. If you have specific questions about your installation please consult an ABYC certified installer.

© Copyright 2017 Blue Sea Systems Inc. All rights reserved. Unauthorized copying or reproduction is a violation of applicable laws.

NAVICO
GROUP

ABYC
Setting Standards for Safer Boating

BATTERY BASICS

Model Battery Size/Type Minimum Runtime

RTSC12DOME 300 Ah Lithium Battery 5 Hours (including 12V DC pump)

RTSC12DOME 600 Ah Lithium Battery 10 Hours (including 12V DC pump)

WIRING DIAGRAMS

FULL 12V DC SYSTEM

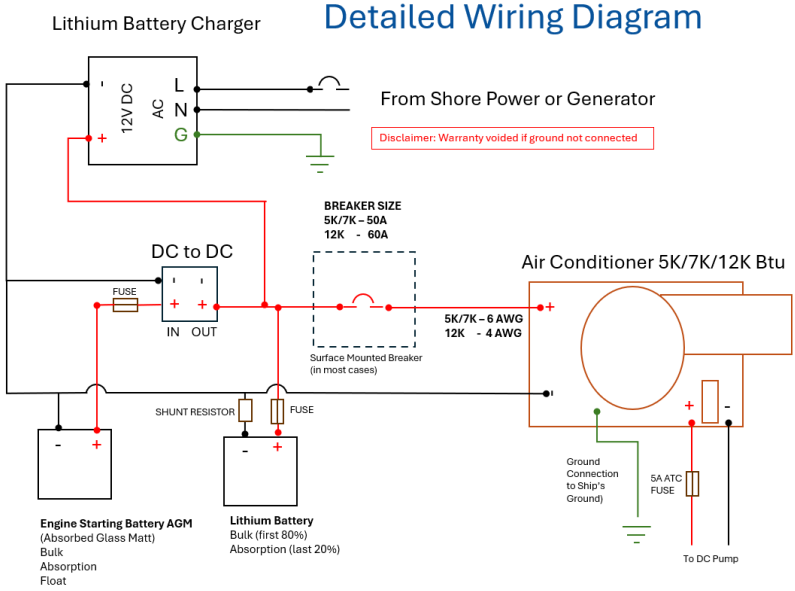

WIRING DIAGRAM FOR RADAIR™ RT12DC

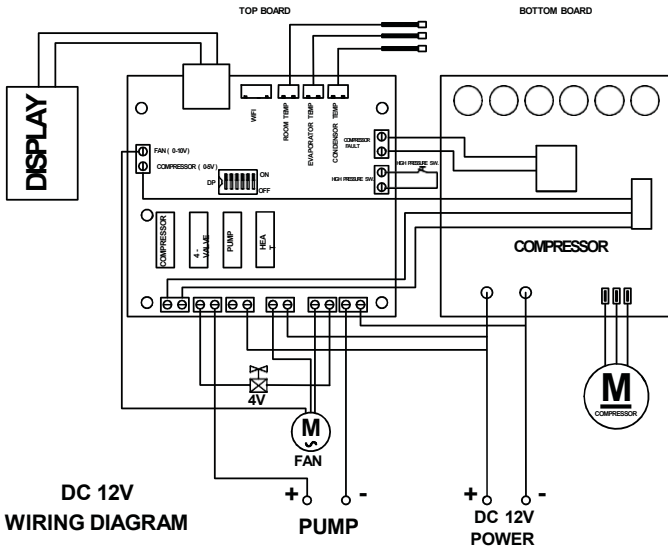

WIRING DIAGRAM FOR 12 V DC SEAWATER PUMP

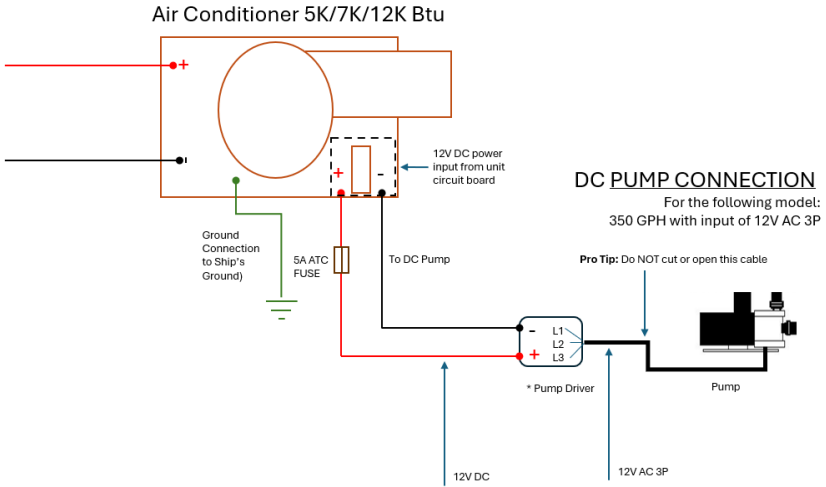

QUICK START/ OPERATIONS CHECKLIST

1. Ensure that the vessel is fully in the water and floating.
2. Ensure that the intake seacock is fully open and that the intake strainer is clear and free of any debris.
3. Inspect the intake components for salt buildup and/or corrosion which would indicate a water leak.
4. Turn on the circuit breaker. If the seawater pump has a separate circuit breaker, turn it on as well. The seawater pump will be on a separate breaker only in the event that a single pump is feeding multiple units.
5. Turn on the air conditioner with the included display by pressing the power button.
6. Set the desired temperature on the included display, making sure that the correct mode is selected (cool, heat, or fan only).
7. Check for a steady flow of water from the overboard discharge. If there is no water pumping overboard, verify that the intake is open and if yes, the pump may be airlocked. To bleed the air out of the pump, open the bleeding valve (if equipped*) until a steady stream of water comes out. Otherwise, the hose on the discharge of the pump must be removed to remove air from the pump. If removing the hose, the intake valve and pump must be off. Once hose is removed, open the valve until there is a clear stream of water and reinsert the hose while keeping the valve open. Once the clamps are secure, turn the pump back on and verify the overboard water flow.
8. Verify cold (or warm) airflow from vents and that enough vents are open for the unit to function as designed.
9. The units are designed to operate with sea water temperatures up to 95 degrees Fahrenheit in cool mode and down to 50 degrees Fahrenheit in heat mode.



*The Bleeding Valve Kit (above) is included in the RadAir™ Basic Installation Kit (Sold Separately). Bleeding Valve Kit may also be purchased separately **SKU# BV58**

DISPLAY MENU OPTIONS

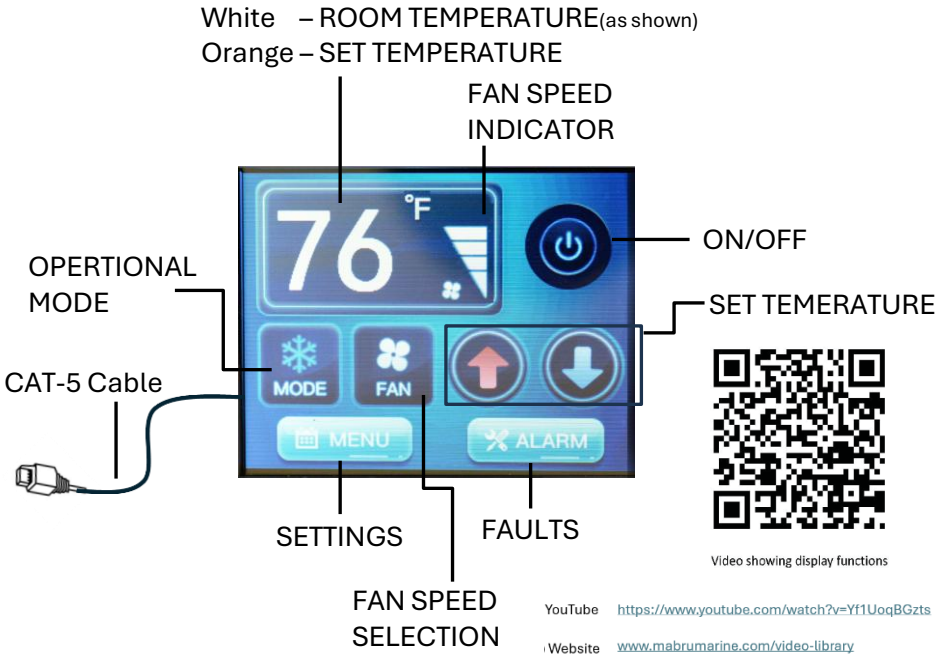

Compressor, pump, heat and valve have a toggle that shows what components are being powered. Heat will never show ON, as it is for electric heat. Valve will show ON when heat is activated, as the units are heat pumps.

There are (3) temperatures displayed under MENU. These are return (reading from return air sensor), evaporator (reading from evaporator sensor, located on the evaporator coil), and cooling water or condenser (reading from condenser sensor, located on the condensing coil). The condenser is expected to read a temperature of no

more than 15 degrees higher than inlet seawater temperature.

Control fan OFF as set from factory means that the fan will always be on, regardless of compressor state. It will slow down when compressor is off if set to AUTO. Control fan ON, the fan will not run if the compressor is off.

Temperature format: To change between temperature measurements, go to MENU and scroll down to TEMP FORMAT. There you can toggle between C or F.

OPTIONAL ADD-ON: MABRU WIFI MODULE

SKU: MWIFICM

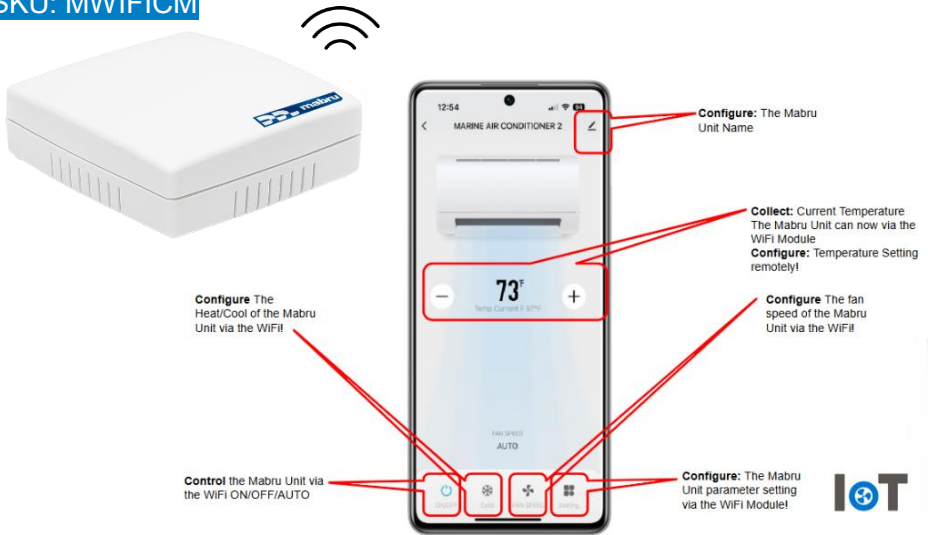

1:1

- Every MABRU Air Conditioning Unit requires a separate *MABRU WiFi Module*.
- Eliminates a single point of failure
- Simplifies integration and setup
- WiFi Modules can be powered on individually to make logical association within a single software platform



Download WiFi Module Specifications

PREVENTIVE MAINTENANCE & WINTERIZATION

WEEKLY

- Check/clean the sea strainer
- Make sure that drains are free-flowing and that no more than ½" of water is sitting in the drain pan.

ANNUALLY

- Visually inspect the unit for any signs of corrosion or damage.
- Blow out drain line(s).
- Descale seawater cooling loop.
- Check all hose clamps and visually inspect all hoses for kinks, cracks, or chaffing damage, replace as needed.

WINTERIZATION

WHEN THE BOAT REMAINS IN THE WATER:

For in-water storage, it's essential to use a potable anti-freeze solution in both the water supply and discharge lines. Ensure compliance with state, local, and federal regulations before discharging antifreeze overboard.

1. Close the ball valve.
2. Disconnect the water line at the ball valve.
3. Submerge the line into a bucket of potable antifreeze.
4. Run the air conditioner until a consistent stream of antifreeze is discharged overboard.
5. Reconnect the water line at the ball valve.

WHEN THE BOAT IS OUT OF WATER IN DRY STORAGE:

When the boat is out of the water:

1. Open the seacock to allow all water to drain from the system through the thru-hull fitting.
2. Remove and empty the seawater strainer basin.
3. Loosen the screws on the pump head to facilitate water drainage from the pump and the water line between the pump and strainer.
4. Close the seacock.

WHEN RETURNING THE BOAT BACK INTO THE WATER IN THE SPRING:

1. Gradually open the seacock to allow water to fill the system up to the pump's level.
2. Tighten the pump face to establish a seal.
3. Once the pump is primed, fully open the seacock valve.

DIMENSIONS

RadAir™ RTSC12DOME

DIMENSIONS

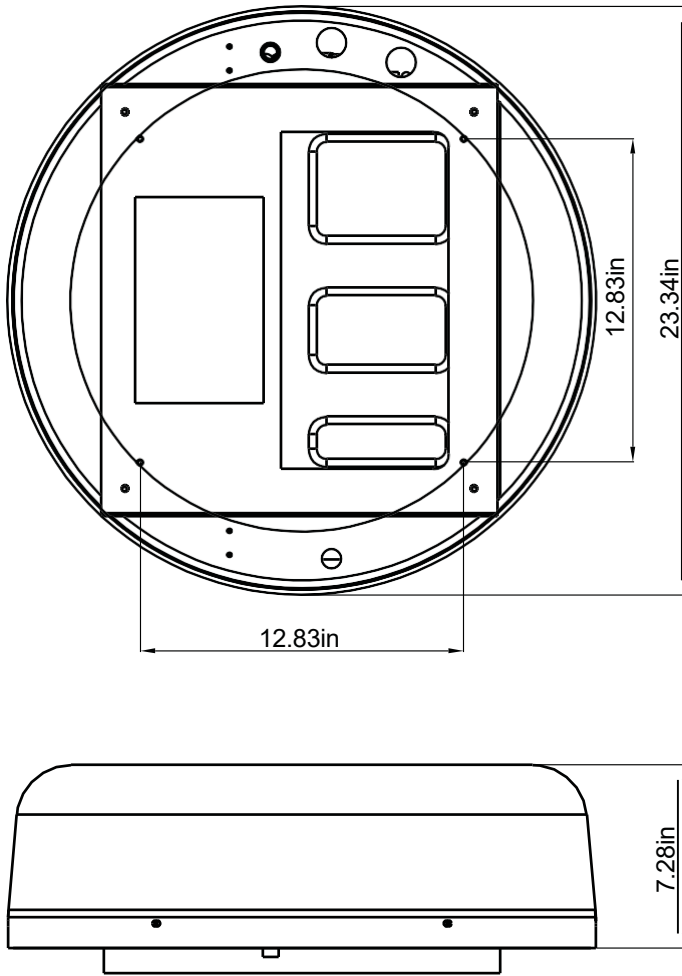

PARTS DIAGRAM

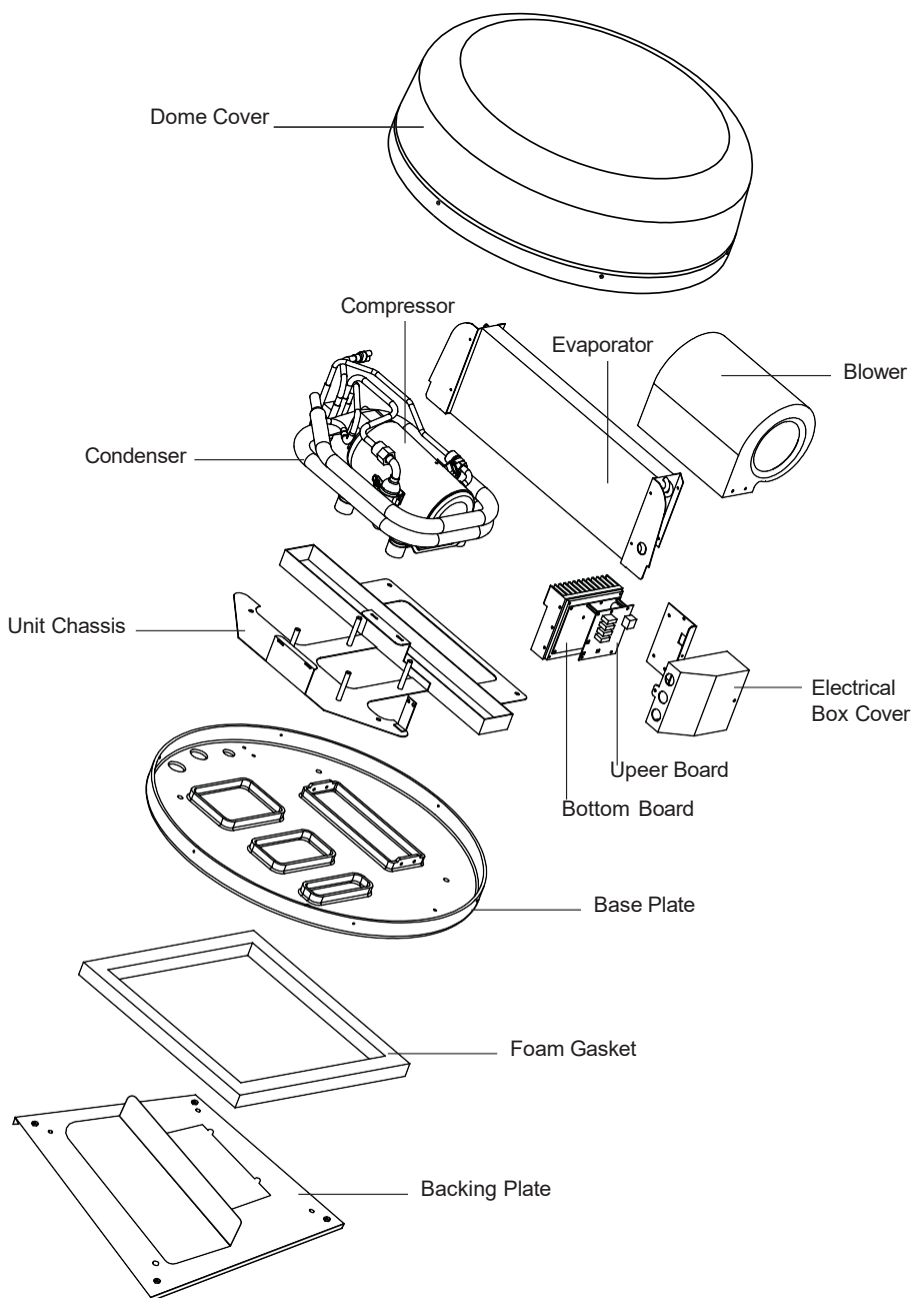

MABRU

ERROR CODES & MARINE TROUBLESHOOTING GUIDE

Error Code	Definition of Error	Possible Causes	Possible Corrections
1	Return temperature sensor error reading (Sensor should be located in front of the return vent)	<ul style="list-style-type: none">• Possible failure of room temperature	<ul style="list-style-type: none">• Confirm RJ45 terminals• Replace display cable (standard CAT5)• Replace return temperature sensor
2	Evaporator temperature Sensor error	<ul style="list-style-type: none">• Possible damage or disconnected evaporator temperature sensor	<ul style="list-style-type: none">• Check connections• Confirm the (blue) A12 connector in place• Replace sensor
3	Condenser (seawater) temperature sensor error (Located on condenser coil)	<ul style="list-style-type: none">• Possible damage or disconnected condenser temperature sensor	<ul style="list-style-type: none">• Confirm condenser temp sensor in place. Replace if necessary• Confirm A13 connector is in place
4	Evaporator high temperature alarm (in heat mode only)	<ul style="list-style-type: none">• Air not circulating through unit• Clogged return grille• Fan isn't working	<ul style="list-style-type: none">• Clean return grille and filter• Check for air restriction in ducting• Confirm fan is working
5	Possible refrigerant leak	<ul style="list-style-type: none">• Evaporator sensor out of position• Refrigerant leak• Condenser temp. too high• 12V models: error could be caused by voltage outside of operating range - 11.5-14.2	<ul style="list-style-type: none">• Evaporator sensor should be placed inside copper tube midway up evaporator• Additionally, for 12V DC models: turn off main breaker for 5 minutes (hard reset). Check voltage parameters; try again.• Verify condenser (cooling water) temp is below 110° F & verify voltage

MABRU

ERROR CODES & MARINE TROUBLESHOOTING GUIDE

Error Code	Definition of Error	Possible Causes	Possible Corrections
6	Error 6 on 12V DC models only	<ul style="list-style-type: none"> Typically caused by voltage or water flow 	<ul style="list-style-type: none"> Verify voltage Restart unit through circuit breaker To confirm flashing sequence: Turn on unit Look for flashing light on electrical box near cable inputs The sequence will flash for one minute, then return to standby mode of one short, one long Contact Mabru support and report sequence
8	High pressure protection	<ul style="list-style-type: none"> In cool mode only: Seawater restriction Seawater pump is broken or airlocked In heat mode only: Air restriction in duct Clogged or blocked return grille Fan not working 	<ul style="list-style-type: none"> Clean seawater strainer Bleed seawater pump Possible descale Repair restriction in ducting Clean return grille Confirm fan working
9	Evaporator protection	<ul style="list-style-type: none"> In cool mode only: Poor air circulation Clogged return grille In heat mode only: Air restriction in duct Clogged or blocked return grille Fan not working 	<ul style="list-style-type: none"> Repair restriction in ducting Clean return grille Change direction of supply grille, if air gets colder
10	Condenser Temperature Error	<ul style="list-style-type: none"> Seawater restriction Operation mode is wrong - cooling mode in a cold climate or heating mode in a warm climate 	<ul style="list-style-type: none"> Check flow at seawater thru-hull Bleed seawater pump Backflush or descale the system. Check if selected mode is correct

MABRU

ERROR CODES & MARINE TROUBLESHOOTING GUIDE

Error Code	Definition of Error	Possible Causes	Possible Corrections
12	12V DC models: Low voltage protection - shown as "return gas sensor fault"	<ul style="list-style-type: none">• Voltage below 10.5 volts to unit• Possible loose connection• Low battery voltage	<ul style="list-style-type: none">• Confirm proper connections• Adjust voltage supply to unit• Charge battery bank
15	Communication error between circuit board and display panel	<ul style="list-style-type: none">• Display control, RJ45 display cable CAT5, or circuit board is damaged• Possible water intrusion	<ul style="list-style-type: none">• Check if the display control panel, RJ45 cable, and/or circuit board was affected by moisture

NOTE: If the display reads -4 or -40 for any temperature readings, it could be an issue with the display cable or the sensor itself. Verify that the display cable is seated properly on the display and circuit board; if that does not resolve the issue, try a new CAT5 (ethernet) cable.



To speed up troubleshooting, please email the following information to: support@mabrumarine.com

1. Your contact information, name, email, and phone number
2. Model and Serial Number
3. Pictures of your installation
4. Any error code that is seen on the display.
5. Pictures of the 2 display screens or the information displayed there. Please include the information at startup and after running for 10 minutes.

- Compressor on or off
- Pump on or off
- Valve on or off
- Return temperature
- Evaporator temperature
- Scroll down to the next screen
- Condenser temperature or cooling water temperature
- Comp Current, this is the voltage on a DC model or the amperage on the VI models.
- Temperature Format
- Control Fan on or off



This is an example of an obstructed pump impeller. This was caused by a poorly maintained sea strainer. The symptom in this case was the substantial reduction in waterflow.

SERIAL NUMBER PLACEMENT

The unit label with the SN is located on the bottom of the base plate and located on top of the electrical box cover on

units sold as of April 2025. Please see examples below of the SN placement on the RadAir™.

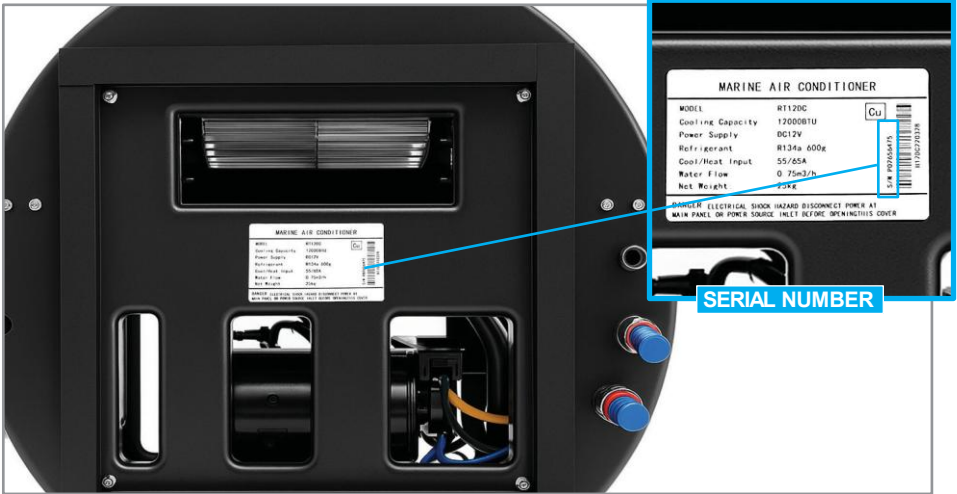

SN location 1: Bottom of Base Plate



SN location 2: Electrical Box Cover (As of April 2025)

WARRANTY AND RETURN POLICY

Below are links to view or download Mabru's Warranty and Policy documents.

MABRU SHIPPING GUIDE & RETURN POLICY:

<https://www.mabrumarine.com/support-marine>

<https://www.mabrumarine.com/support-rv>



MABRU GENERAL PRODUCT LIMITED WARRANTY :

<https://www.mabrumarine.com/support-marine>



MABRU RV PRODUCT LIMITED WARRANTY :

<https://www.mabrumarine.com/support-rv>



MABRU LITHIUM BATTERY WARRANTY :

<https://www.mabrumarine.com/support-marine>



All warranty documents and policies can also be requested directly from our team.

MABRU CUSTOMER SERVICE DEPARTMENT

For customer and technical support, contact
Mabru using the following:

Telephone: +1 888-818-2814
+1 954-467-1770

Email: sales@mabrumarine.com

Mailing Address:

Mabru Power Systems
Warranty Department
1105 Old Griffin Road,
Dania Beach, FL 33004

For all other areas, visit our website to find
your nearest distributor:

www.mabrumarine.com

[We are open M-F 8:00AM to 4:30PM ET](#)



This manual and its contents, including but not limited to text, images, and videos, are the property of Mabru Power Systems and protected under the Copyright Act. Reproduction or distribution of any part of this copyrighted content without permission is prohibited.